

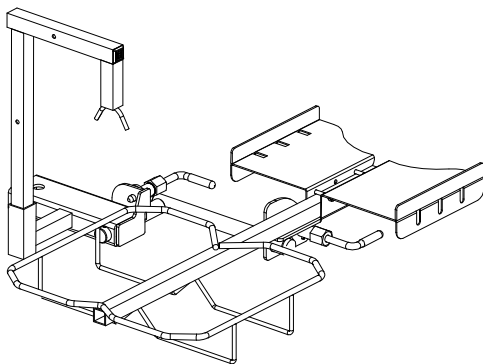

7325 Douglas Rd.
 Lambertville, MI 48144
 Phone: 1-800-541-3213
 Fax: (734) 568-6705
 www.WheelChairCarrier.com

Tilt 'N' Tote [Model 001], Tilt 'N' Tote Plus [Model 004] & Tote [Model 003]
 Folding WheelChair Carrier
Installation Guide & Owners Manual

Tilt 'N' Tote [Model 001]

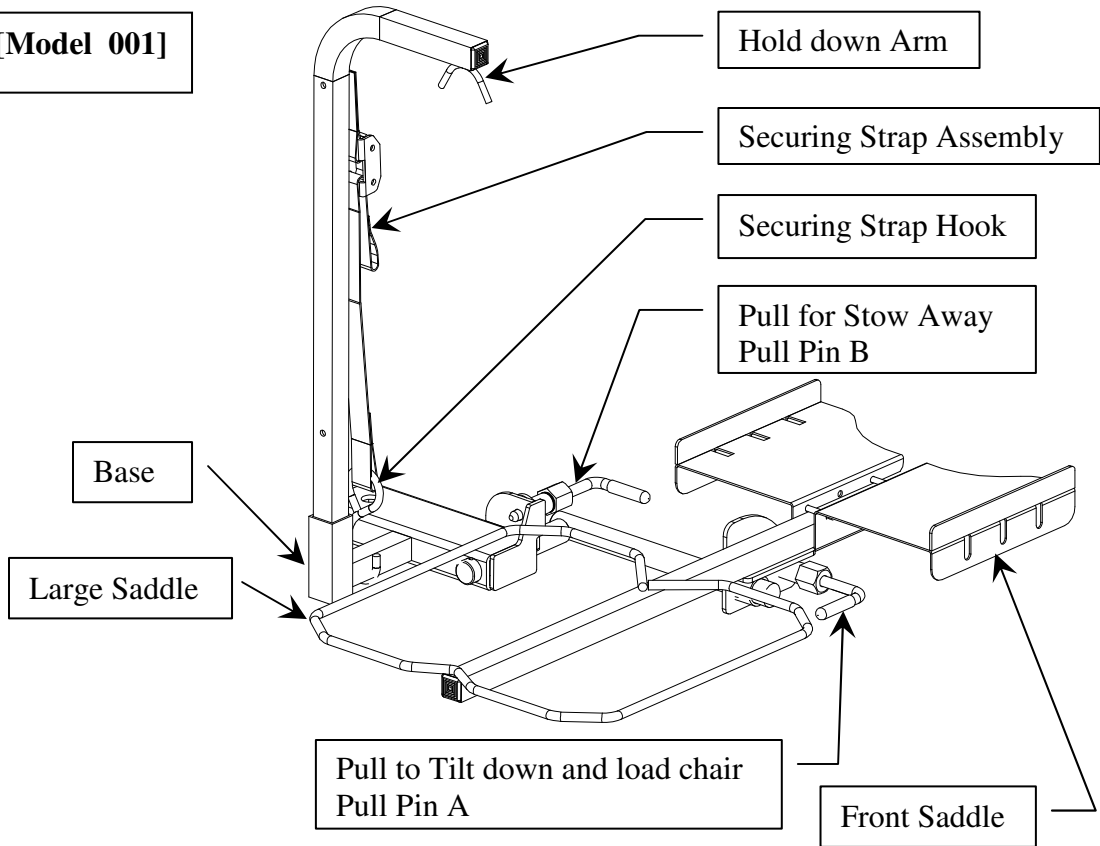

Tilt 'N' Tote Plus [Model 004]

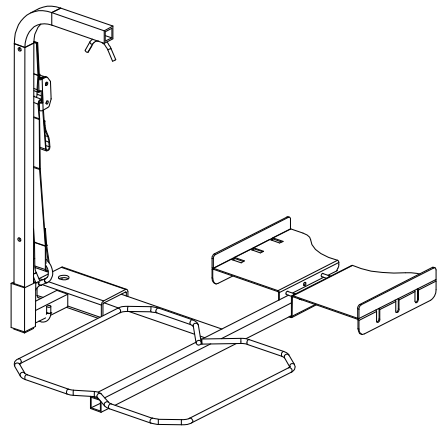

Tote [Model 003] Non folding



CAUTION: Read and follow all Installation Instructions and Operating Instructions before the first use of this product.

Save this manual for future reference. Rev. Original 06-10-05 / Rev. E 04-04-11

Introduction

Congratulations on your new *WheelChair Carrier* product purchase! The Tilt 'N' Tote carrier is the easiest way to transport your folding wheelchair. The Tilt 'N' Tote Plus will accommodate folding wheel chairs with 8" to 13" Diameter Wheels, and with a separate locking arm it can accommodate a standard 24" folding wheelchair. The Tote is a space saving carrier for your wheelchair. This manual has been written to be used as an installation guide as well as an operation guide for the end user.

Both installers and operators should read all of the available manuals thoroughly before attempting any installation, operation, or maintenance of the Tilt 'N' Tote carrier.

If you have any questions or comments concerning the installation or operation of this carrier, please contact your local dealer or *WheelChair Carrier* for additional technical information.



DANGER: Some folding wheelchairs may be unsuitable for transport on a Tilt 'N' Tote carrier. Please be sure that the chair meets the size constraints set for each product. Never exceed the posted weight capacity [**100 lbs**] of the carrier.

Unpacking the Carrier

Detailed below is the inventory of parts included with your carrier. If any parts are missing or if any shipping damage is noted, immediately contact your dealer or *WheelChair Carrier* if purchased direct. **DO NOT** attempt to install or use the lift with any missing or damaged parts.

Tilt 'N' Tote Carrier Box Contents:

- (1) – Carrier Assembly
- (1)– 15" Bungee Cord
- (1) – 3/4-10 x 3-1/2" Hex Bolt
- (1) – 3/4-10 Lock Nut
- (1) – 3/4" Lock Washer
- (1) – Hold Down Arm
- (1) – Anti Rotation Bracket
 - Accessories
 - 022 Cover - Protects both wheelchair and carrier

- 302 Class 2 [1-1/4"] Ball Mount
1/2" Pin with Clip Included

- 303 Class 3 [2"] Ball Mount
5/8" Pin with Clip Included



Sold Separately

Installation Instructions

- The Tilt 'N' Tote carrier requires a minimum Class 1 trailer hitch with a Ball Mount. For proper standard installation, any existing tow ball must be removed from the hitch. If you need assistance in choosing the correct hitch for your vehicle, contact your local hitch dealer such as U-Haul®. There are also many web sites on the internet that offer complete hitch guides and hitch search engines using your specific vehicle information. Below are a few sites that may be helpful.
<http://www.uhaul.com> <http://www.hitchfinder.com> <http://www.draw-tite.com>



IMPORTANT: Every hitch bears a different amount of tongue weight.

NEVER exceed the tongue weight capacity of your hitch.

[Tongue weight = the weight of the carrier + the weight of the chair on the carrier.]

- **For the best performance**, the carrier should be mounted at a height of **9 to 13** inches above the ground. The Tilt 'N' Tote should be mounted at a height which is comfortable for lifting the wheelchair off the ground. The carrier may be mounted either above or below the draw bar to ensure proper ground clearance. If your carrier is equipped with a hitch adapter accessory then the accessory can be rotated to achieve variable ground clearance.
- If using the anti-rotation bracket then place it above or below the draw bar. Make sure that the holes on the anti-rotation bracket and the draw bar are aligned. The anti-rotation bracket must lay flat on the draw bar.

NOTE: The carrier comes with a standard anti-rotation bracket to fit on a drawbar that measures under 2-1/2" wide. Please be sure to purchase this size draw bar when purchasing a trailer hitch. Some class 3 hitches have an extra wide drawbar that measures over 2-1/2" in width. If this size drawbar is encountered, please contact your local dealer or *WheelChair Carrier* and the proper anti-rotation bracket will be provided to you.

- After the carrier is installed make sure that it is secure and that the carrier does not move side to side.
- Make sure all of the pivot points and the latching mechanisms are properly greased and move effortlessly.
- Make sure the unit easily tilts to the ground and folds up to the bumper of the vehicle.

SPECIFICATIONS:

Product Weight: 22 lbs

Maximum Capacity: 100 lbs

Class Hitch Required: 1, 2, or 3

Size Capacity: 15-1/2" x 29"

Works with: Standard Folding Wheelchairs

Recommended Hitch height: 9"-13"

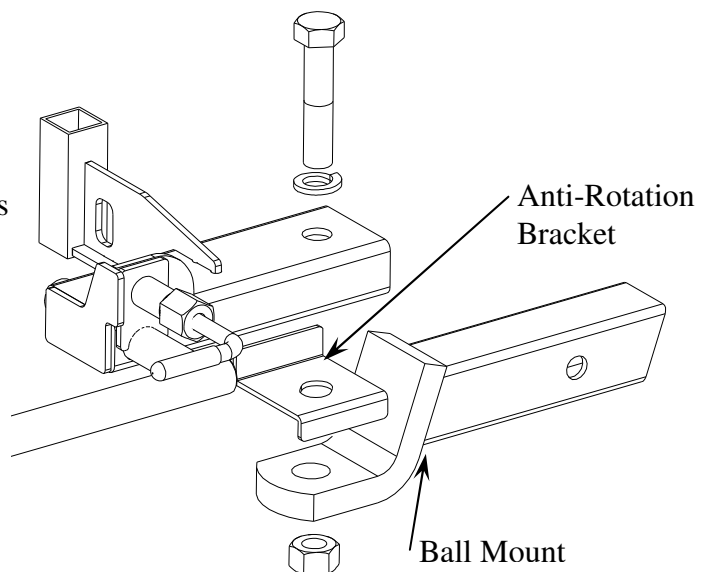

Operation Instructions

- Tilt the carrier to the ground using Pull Pin-A. Roll the chair into the carrier so rear wheels are contained in the large wire form saddle. Tip the chair and carrier forward until Pull Pin-A snaps back into position.
- Secure the front wheels with the strap provided. Do this by putting the strap over or through the front wheels. Make sure that both sides of the strap are secure. Double check the pull pin to make sure it has snapped back into position.
- Insert the end of the Hold Down Arm into the base. The prongs of the Arm should be over the back wheel of the chair. Insert the Securing strap hook over the 1” tubing. Pull the strap tight. Do not over tighten the strap. This may cause the wheel to warp.

FRONT WHEEL ADJUSTMENT

After loading your chair into the carrier, slide the front saddle to the position that fits your chair. Tighten the Bolts to secure the front saddle.



IMPORTANT: Always verify that the wheelchair is secure before operating the vehicle.

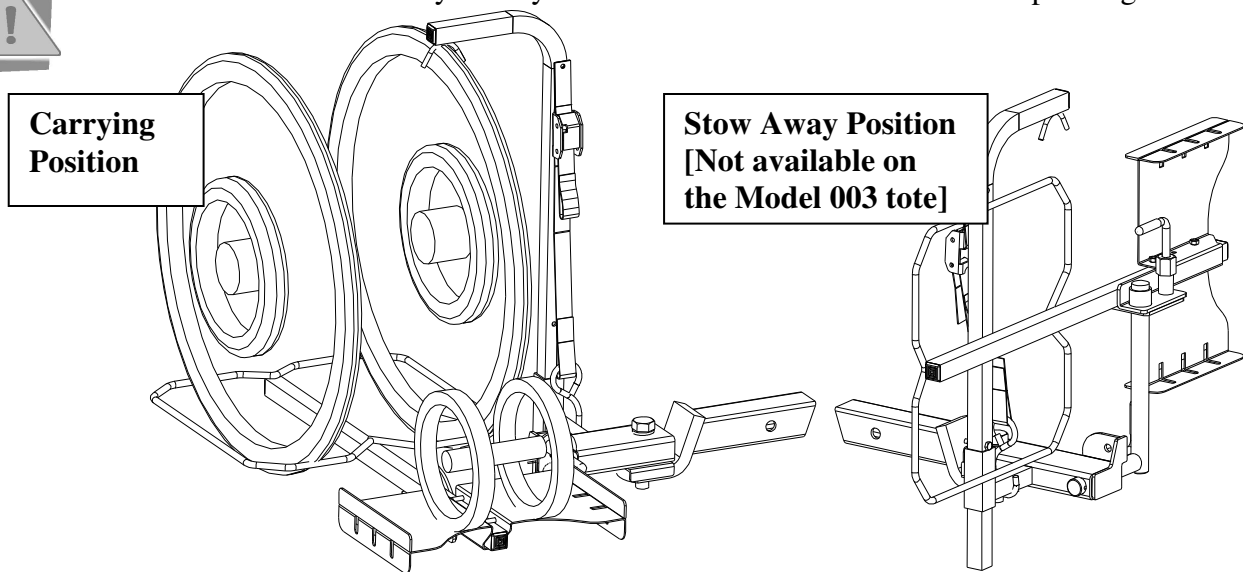

Storing the Carrier

When not in use, the Tilt ‘N’ Tote can be folded up toward the bumper of the vehicle in its’ “stow away” position.

- The carrier tilts up to the “stow away” position by pulling Pull Pin-B and rotating the carrier up toward the vehicle.
- Make sure that Pull Pin-B snaps into the locking position and that the carrier is secure when in the “stow away” position.
- The Hold Down Arm can be left in base with the securing strap fastened down, or removed to store in trunk for storage.

Safety



Caution: Do not operate the carrier without being satisfactorily instructed in the proper operation of the carrier by the dealer or without reading and understanding the operation manual.

- Our wheelchair carriers have been designed, engineered and tested for years of trouble free performance. However, with everyday use some parts may become loose or worn. Regularly inspect your carrier for any worn, loose, or damaged parts. If you find anything upon inspection, **DO NOT USE THE CARRIER!** Contact your local dealer or *WheelChair Carrier* for any repairs that need to be made. **Failure to act may cause severe injury!**
- Our wheelchair carriers must only be used for the loading and unloading of wheelchairs for which it is designed. **DO NOT** add to or modify any part of the carrier system without first contacting the manufacturer of the carrier. Any modifications may void any warranties as well as compromise the structural integrity of the carrier.

Maintenance

Our wheelchair carriers have been designed to be as trouble free as possible for the owner. As with any mechanical device however, maintenance should be performed regularly while owning and operating our carriers.

- *WheelChair Carrier* recommends that dealers schedule a preventative maintenance inspection at least once a year on the carrier frame, and all moving parts of the carrier.
- Regularly check and tighten all hardware on the carrier.
- Regularly check paint and touch up any bare metal with a good gloss enamel or lacquer to inhibit rust. *WheelChair Carrier* recommends checking your carrier frequently if it is subjected to salt air or road salt for any period of time.



WheelChair Carrier

Taking You Where You Want To Go...

3 YEAR TRANSFERABLE WARRANTY

Every effort has been made to insure high quality in material and workmanship of our products. Manufacturer warrants all products to be free of defects in material and/or workmanship for three (3) years from date of original purchase. **EXCEPTIONS:** All custom orders have a 90~day warranty.

CARRIERS: All carriers are warranted to be free of defects in material and/or workmanship for three (3) years from date of original purchase when used in accordance with manufacturer installation and operating instructions. This warranty does not cover damage due to abuse, misuse, accident, or use of unauthorized attachments or modifications. Protective finish coating on carriers is not guaranteed in as much as the manufacturer is not responsible for the use (abuse or natural wear and tear) of the product. The manufacturer and/or selling agents of carriers will not be responsible in any way for damage to, or loss of, item(s) being carried or falling from carriers or damages said item(s) may cause on or off carriers.

TRANSPORT COVERS: Transport covers are guaranteed free of defects in material or workmanship at purchase. Covers are not guaranteed against rips, holes, or damage due to improper installation, abuse, misuse, alteration, or environmental factors beyond our control.

RETURN POLICY

All returns must be made within 30 days from the date of purchase unless due to defect. Written authorization **MUST** be obtained from *WheelChair Carrier, Inc.* prior to the return of any merchandise for any reason, and all transportation costs must be prepaid. **NO RETURNS** on custom orders. Authorized returns for credit only are subject to a 25% restocking charge, plus any cost incurred in restoring the merchandise to a resalable condition. Freight charges cannot be credited.

WHEELCHAIR CARRIER, INC.

7325 Douglas Rd.

Lambertville, MI 48144

PHONE: (734) 568-6084 or call toll free at 1-800-541-3213

FAX: (734) 568-6705

www.WheelChairCarrier.com